



# Sideshift backhoe

E



## Technical Specification



**Sideshift backhoe** with **hydraulic locks** suitable for digging flush with walls.

**Hydraulic independent outriggers.**

Matching with skid loaders; **controls inside the op-**

**erator's cab.**

Standard backhoe bucket.

**Auxiliary hydraulic** lines on dipper stick on request.

# Sideshift backhoe

MODEL		E 250	E 280	E 320
<b>Technical specification</b>	<b>um</b>			
Max digging depth	mm	2450	2800	3250
Oil flow, min-max	lt/min	20-30	35-45	40-50
Rated oil pressure	bar	160	165	
Weight standard configuration	kg	550	680	820
Bucket width standard	mm		300	
Breakout force at bucket tooth	mm	1850	2500	3200
Standard frame width	mm	1300	1500	1600
Total swing			180°	
Control valvebank sections	n.		6	
Slewing hydraulic lock			standard	
A			195°	
B	mm	3080	3620	3995
C	mm		420	470
D	mm	1460	1620	1780
E	mm	2450	2800	3200
F	mm	2150	2400	2550
	ton	1,7-2,2	2,2-3,4	3,4-4,8

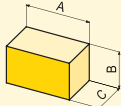
	Overall size in standard configuration	A cm	160	165	180
		B cm	190	220	230
		C cm	80	90	100

## WORKING DIMENSIONS

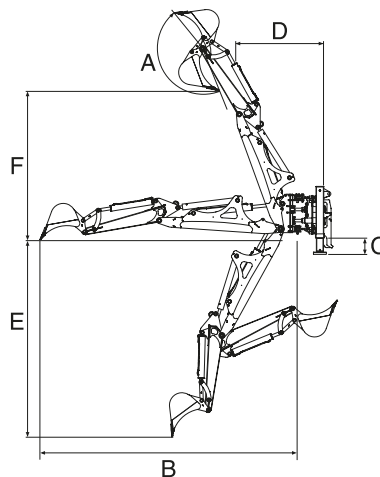

**On request**  
Auxiliary line for hydraulic breaker

## ACCESSORIES FOR OPERATING MACHINES



Via E. Mattei, 4 - 48012 Bagnacavallo RA - Italy  
tel + 39 0545 62712 fax +39 0545 62140  
info@gfgordini.com - www.gfgordini.com

**YOUR BEST CHOICE SINCE 1985.**

